

CAT® GROUND ENGAGING TOOLS



FOR CONSTRUCTION



MADE FOR YOUR APPLICATION.

Protect expensive machine components. Reduce your operating costs. And get the most out of your machine's performance.

The most important part of any machine is its work tool. Buckets or blades, tips or edges, rippers or side cutters—no matter the size, worktools and G.E.T. are the main reason the machine exists. Ground engaging tools have a direct effect on the machine's ability to produce. Improper selection affects not only your productivity, but your fuel consumption, maintenance costs and possibly the longevity of your equipment.

Caterpillar offers "off-the-shelf" and custom G.E.T. systems that maximize machine productivity, and your Cat® dealer can help you establish an effective management program that minimizes preventable problems—working to reduce your operating and maintenance costs.

Use this catalog to learn more about what's available for your equipment, then work with your Cat dealer's G.E.T. specialist or PSSR to select the components built for your industry and jobsite conditions. We'll make sure you get the rugged durability, solid protection and lowest cost-per-ton production system you need.

BUILT FOR IT.™



Dozers

Cutting Edge & Blade Protection	7
Ripper System.....	13

Motor Graders

Cutting Edges.....	25
End Bit System.....	37
Ripper-Scarifier System.....	39

Hydraulic Excavators

Tip & Adapter Systems.....	47
Base Edge Systems	61
Side & Edge Protection.....	65
Rip & Load System.....	75

Wear Parts & A.R.M.....	77
------------------------------------	-----------

Part number reference can be found in Appendix (PEBJ0079)



DOZERS

No other manufacturer in the world has more experience moving material than Caterpillar. We invented the dozer over 100 years ago—and we've been the market leader ever since. There are more Cat Dozers at work in the world than any other brand.

Dozers work in dozens of different industries, applications, climates and environments and can be customized for specific jobs—just like the G.E.T. that protects their blade or ripper system. For parts availability to expert support and service, Cat customers can count on one reliable source—Caterpillar and Cat dealers.



SYSTEM OVERVIEW

Dozers move ground at mines, construction sites, residential developments and hundreds of other places. A dozer's main work tools are a blade and a ripper. The universal blade is curved, wide and tall so that it can carry material. Other blades are flat or shorter, but they all do a similar job: leveling the ground. The ripper loosens the rocky or compact earth, which makes dozing or loading easier.

Both the blade and ripper have to balance ground penetration with wear life. Excessive worktool or G.E.T. wear material can make the machine less effective. Cat dozer cutting edges and end bits are designed as a balanced system to move more material over a longer period with less downtime—which translates into a lower cost per hour for you. Select from dozens of ripping system configurations, or have your Cat dealer help you choose the best option for your application.



CUTTING EDGES & END BITS

BALANCED EDGE SYSTEMS FOR EVERY APPLICATION.

Matching your cutting edge wear rates with your end bit selection is easy with our broad portfolio of options. You achieve a balanced system, which helps reduce both maintenance intervals and operating costs, leading to more productivity.

Cat end bits and cutting edges can be custom ordered with Cat Abrasion Resistant Material (A.R.M.), which is recommended for applications where sand, gravel or other abrasive materials severely diminish wear life. Hard tungsten carbide particles are bonded to critical wear areas, providing up to five times greater wear life than similar end bits and cutting edges without A.R.M. See your Cat dealer for details.

SAFER, SIMPLER INSTALLATION

Threaded holes allow easier handling of edges at first install or during rotation to wear opposite edge.

MINIMAL THROW AWAY

Multiple edge sections allow you to rotate or replace only the worn areas.

IMPROVED PRODUCTIVITY

Broad offerings allow you to have both end bit penetration and long cutting edge life, resulting in less maintenance.



CUTTING EDGE & END BIT OPTIONS

We have G.E.T. for your blade, no matter the application or environment. As machines grow larger, their jobs become tougher, and so does Cat G.E.T. Maximum wear life and breakage resistance is possible with our steel alloy that can endure 2x the heat and pressure of traditional blade steel products. Consult your local Cat dealer to help determine the best cutting edge system for your application to give you the lowest cost per hour.

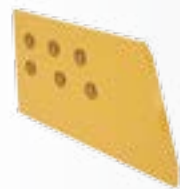

FINISH DOZING (LEVEL CUT)

- Recommended for finish and semi-finish dozing
- Matches cutting edge's depth of cut
- Low-impact, low-abrasion materials only



UTILITY

- Lower initial price
- Flat plate design for applications where face wear is a continuing problem
- Acceptable in impact and high abrasion



GENERAL PURPOSE

- Baseline for other end bits (factory fit)
- Sharpened, forward-protruding profile for excellent penetration



EXTENDED WEAR LIFE (EWL)

- 25% more usable wear material than General Purpose end bits
- Prolonged life and excellent penetration in abrasive conditions



EXTREME EXTENDED WEAR LIFE (EOWL) - D10 & D11 ONLY

- 60% more wear material than EWL end bits on D11 (25% on D10)
- The mounting surface is machined for optimum flatness to provide improved bolt retention

A COUPLE MINUTES CAN SAVE YOU HOURS.

Ensuring a long life for your blade and the G.E.T. that protects it involves three simple steps. Clean surfaces, new hardware and proper installation technique are shared as tips and tricks below. Always follow the specific instructions for your machine. Your local Cat dealer is only a phone call away if you need assistance.

1) Clean and Pristine

- Surfaces, bolts and nut threads must be clean to ensure maximum clamping force
- When installing, use new hardware as old bolts may have suffered metal fatigue

2) Center Out

- Cutting edge bolts are installed from the center outward—do not install from both ends toward the center
- End bit bolts are installed first from the center outward, then from the center inward

3) Torque, Bang, Torque

- Tighten all bolts to the required torque
- Wearing safety goggles, seat bolt heads in the countersinks with a heavy hammer
- Tighten the bolts again to required torque

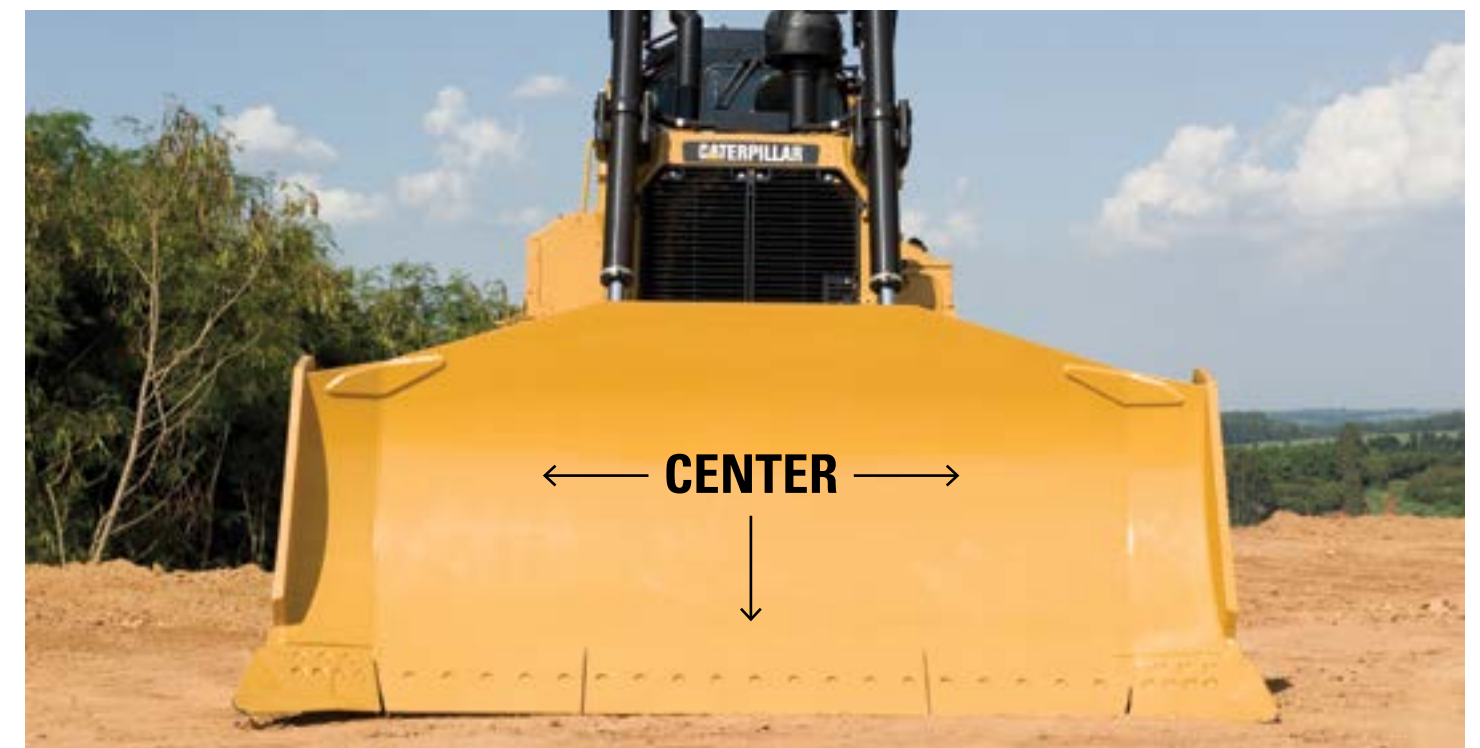

BLADE PROTECTION

PUSH BACK ON COSTLY REPAIRS.

Protect your blades from impact and aggressive wear with the line of Cat blade protection for dozers. All Cat blade products are manufactured to the factory contour, making fit and installation fast and efficient.

REDUCE BLADE DAMAGE

Push plates distribute the high forces created when pushing scrapers.

EXTEND BLADE SERVICE LIFE

Wear plates extend the service life of the blade "skin" in highly abrasive conditions.

SIMPLIFY INSTALLATION

Cat wear bars are 450 BHN and beveled to accept weld bead—a fast way to add strength and protection.

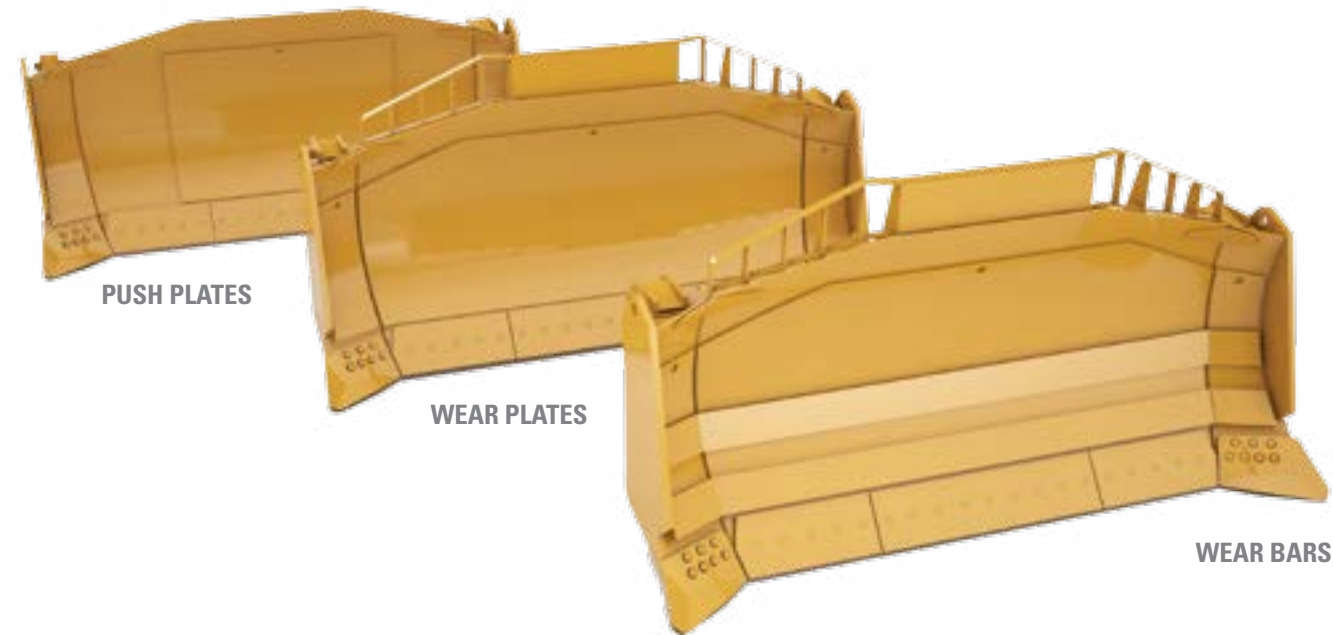

BLADE MAINTENANCE & REPAIR

INVEST IN YOUR FUTURE.

Only a Cat cutting edge support will guarantee dimensional accuracy like the factory originals. Cutting edges and end bits are fastened to your cutting edge support. This bolted connection requires a perfectly flat and smooth surface the full length of the blade to ensure your G.E.T. stays secure. When millimeters matter, count on Cat quality and your Cat dealer's capabilities.

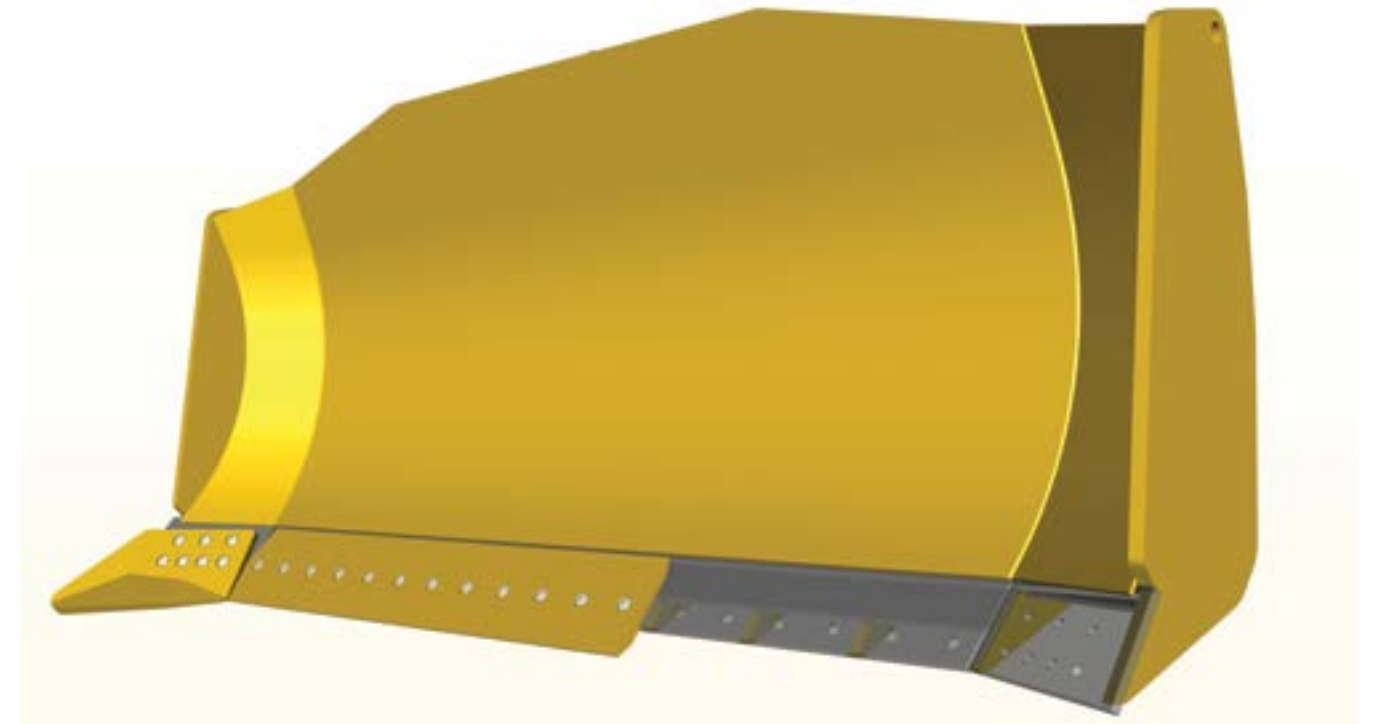

SIDEBAR PROTECTOR

Dozers need sidebar protection, too. Large dozers, like large loaders, work in high-impact and extreme abrasion. Increase carrying capacity and simplify your blade maintenance with hammerless protection. Simply weld in the protector adapter once and save hours each time you replace the sidebar protection.

LOW MAINTENANCE

Protects the blade edge and extends sidebar reach to reduce maintenance cost and increase capacity.

HAMMERLESS

Fast, easy removal and installation.
Reduces risk of injury.

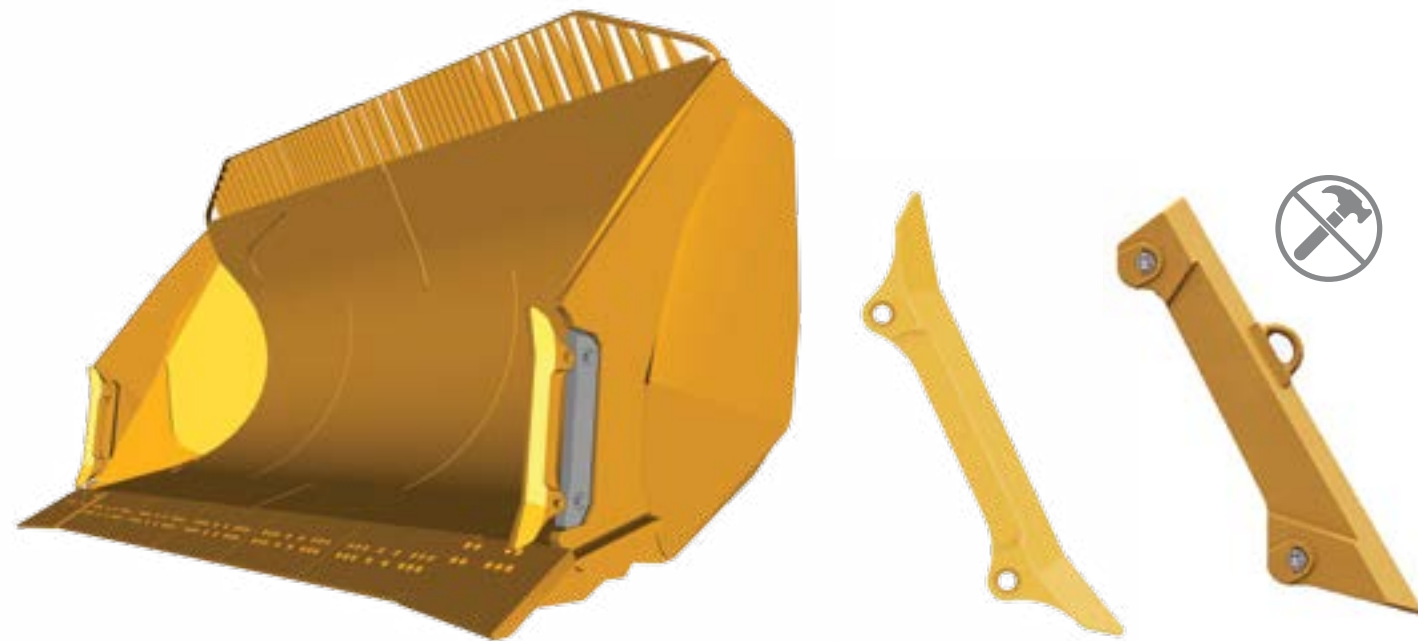

RIPPER SYSTEMS

CAUSE A DISTURBANCE, GAIN PRODUCTIVITY.

Selecting the proper ripping tools can make the difference between just being able to rip a material and being able to reach optimum efficiency and maximum production (lowest cost/yd³). Production ripping (>20% of operation) usually requires a single shank ripper, as do very hard or tightly compacted materials. The more varied the job conditions, the greater the need for the multishank ripper. The multishank is especially useful in pre-ripping for scrapers or other loading tools.

LOWER OPERATING COSTS

Hammerless design allows pin re-use on J style adapters.

HAMMERLESS DESIGN

Fast, easy removal and installation.
Reduces risk of injury.



For more information on ripper systems, please reference [The Handbook of Ripping \(AEDK0752\)](#).

RIPPER SYSTEM AVAILABILITY

Tooth penetration can be the key to ripping success. That's why we offer a variety of tip styles and profiles. Our alloy steel tips withstand higher operating temperatures and are also self-sharpening. Shank protection helps you cut the material and extend your maintenance intervals. The products below are readily available, or you can consult your Cat dealer for custom options.

TIP OPTIONS	R350		R450		R500		R550	
	Side Pin	CapSure	Side Pin	CapSure	Side Pin	CapSure	Side Pin	CapSure
Centerline - Short								
Centerline - Intermediate								
Centerline - Intermediate A.R.M.								
Centerline - Long								
Centerline - Sharp Limestone								
Centerline - Sharp A.R.M.								
Penetration - Short								
Penetration - Intermediate								
Penetration - Intermediate A.R.M.								
Penetration - Long								
Penetration - Sharp								

SHANK PROTECTOR	R350		R450		R500		R550	
	Side Pin	CapSure	Side Pin	CapSure	Side Pin	CapSure	Side Pin	CapSure
Protector - Long (110mm Shank)								
Protector - Std (110mm Shank)								
Protector - Long (100mm Shank)								
Multi pc Sharp & Guard (100mm Shank)								
Protector - Std (100mm Shank)								
Protector - Long (90mm Shank)								
Protector - Std 1 pin (90mm Shank)								
Protector - Std 2 pin (90mm Shank)								
Protector - Long (75mm Shank)								
Protector - Sharp (75mm Shank)								
Protector - Std (75mm Shank)								
Protector - Std (73mm Shank)								

HAMMERLESS RIPPER TIPS CAPSURE RETENTION

Always use the longest tip without excessive breakage. Centerline tips have equal wear material on both sides and can be reversed, which can extend the life and help maintain sharpness. Cat penetration ripper tips have an aggressive angle to break through even the hardest surfaces and dig into the ground more effectively. Both hammerless options feature a topside deflector, which creates a smooth transition with the shank protector.



SHORT CENTERLINE

- Used in extreme impact conditions
- Sacrifices some wear material



INTERMEDIATE CENTERLINE

- Used for moderate impact and abrasion conditions
- 33% longer than Short Centerline



INTERMEDIATE PENETRATION

- Used for moderate impact and abrasion conditions



LONG PENETRATION

- Designed for low-impact, highly abrasive conditions where breakage is not a problem
- 20% longer than Intermediate Penetration

INSTALLATION & REMOVAL

Hammerless removal and installation is possible with your current side pin shank/adaptor system. CapSure™ retention is built into each tip, so you only need to insert a pin to experience faster, safer, and easier tip change out.

1 Insert pin into adapter hole.



2 Insert washer into adapter hole.



3 Slide the tip onto adapter.



4 Turn retainer 180° to lock/unlock.

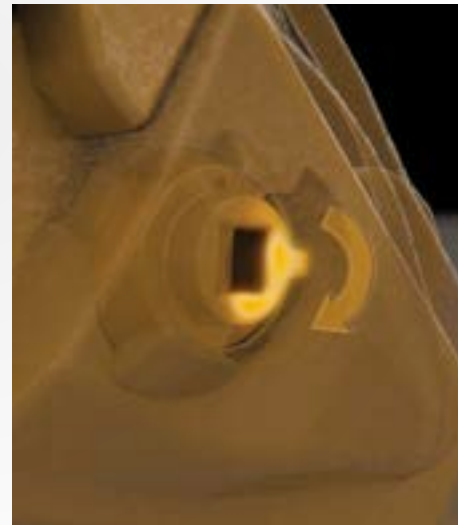

Removal and installation animation is available at www.youtube.com/watch?v=UW6_jjqa_eA or by scanning the QR code to the right.

Scan the QR code to the right to watch the installation video.

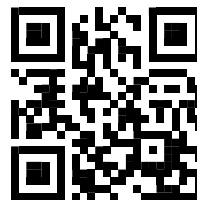

J SERIES TIP OPTIONS

Always use the longest tip without excessive breakage. Centerline tips have equal wear material on both sides and can be reversed, which can extend the life and help maintain sharpness. Cat penetration ripper tips have an aggressive angle to break through even the hardest surfaces and dig into the ground more effectively.



SHORT CENTERLINE

- Used in extreme impact conditions
- Sacrifices some wear material



INTERMEDIATE CENTERLINE

- Used for moderate impact and abrasion conditions
- 17% more wear material than Short Centerline

A.R.M.
OPTION
AVAILABLE



LONG CENTERLINE

- Used in low impact, high abrasion where breakage is not a problem
- 30% more wear material than Intermediate Centerline



SHARP CENTERLINE A.R.M.

- Intermediate Centerline tip, which is tapered to a pick-like point on the end
- A.R.M. strip on one side enhances sharpening action
- Offers best penetration and 13% more wear material than the Short Centerline

A.R.M.
OPTION
AVAILABLE



SHARP LIMESTONE

- Used in limestone or caliche applications
- Chisel point penetrates in hard-to-penetrate materials
- 16% more wear material than Short Centerline and 10mm shorter than Intermediate Centerline tip



SHORT PENETRATION

- Used in extreme impact conditions
- Sacrifices some wear material



INTERMEDIATE PENETRATION

- 17% more wear material and 50mm longer than Short Penetration
- Used for moderate impact and abrasion conditions



LONG PENETRATION

- Used in low impact, high abrasion where breakage is not a problem
- 4% more wear material and 47mm longer than Intermediate

A.R.M.
OPTION
AVAILABLE



SHARP PENETRATION

- Intermediate Penetration length tip
- Factory sharpened to ensure maximum penetration

INSTALLATION & REMOVAL

The J Series Tooth and Adapter system uses the standard pin and retainer system. The Tooth Pin Remover tool is available to make removal easier.

1 Place the tool on the tip and align the extractor with the pin.



2 Strike the tool with a hammer until the pin is removed.



RIPPER SHANK PROTECTOR

WANT BETTER PRODUCTIVITY WITH LESS COST? WE'VE GOT YOU COVERED.

Shank protectors cut through material with sharp edges, lowering the ripping effort. Minimize the wear, and required maintenance, on the more expensive shank body when you guard it with a protector. Never rip without Cat G.E.T. Our hammerless options offer fast, easy removal and installation without specialty tools.

SHARPENED PROFILE

Cuts through tough and compact materials causing lower ripping resistance and horsepower loss.

EXTENDED PROTECTORS

60% more coverage.

FULL LENGTH

Triangle-shaped guard-bar integrates with sharp lower protector for maximum ripping protection.



Single shank machine



RIPPER SHANK PROTECTOR OPTIONS

Four different protection options align with the tractor's ripping system and the most common applications.

GENERAL PURPOSE

- Baseline protector R350 and R450 only



PIN ON

SHARP

- Penetrates compact material better than standard design
- Hammerless option has 40% more wear material than side pin version



ONE PIN

HAMMERLESS

EXTENDED PROTECTOR

- 60% more shank protection than Sharp



PIN ON

HAMMERLESS

INTEGRATED SHARP

- Works with triangle-shaped bar to provide complete shank protection



PIN ON

THREE-PIECE SHANK PROTECTOR

INSTALLATION & REMOVAL

Hammerless retention made simple. The CapSure™ locking system allows for safer and easier removal/installation in four steps.

1

Insert pins and washer into shank hole.



2

Place shank protector over lower pin.



3

Position retainer over upper pin.



4

Turn retainer 180° to lock/unlock.



Removal and installation animation is available at www.youtube.com/watch?v=UW6_jjqa_eA or by scanning the QR code to the right.

Scan the QR code to the right to watch the installation video.





MOTOR GRADERS

We offer hundreds of cutting edge options available on the shelf, plus the ability to customize through our Made as Order (MAO) program. Unique offerings like the Cat GraderBits™ system meet the toughest application needs and are complemented by multiple End Bit options. Trust your Cat dealer to offer you solutions that focus on total machine productivity.



CHOOSING AN EDGE

Edge selection is critical for enhancing production and keeping cost to a minimum. Application affects the cutting edge shape, metallurgy and style. Impact, penetration and abrasion define your application environment. An edge has to penetrate the material and not break during operation. Edge life then becomes a matter of metallurgy and thickness.

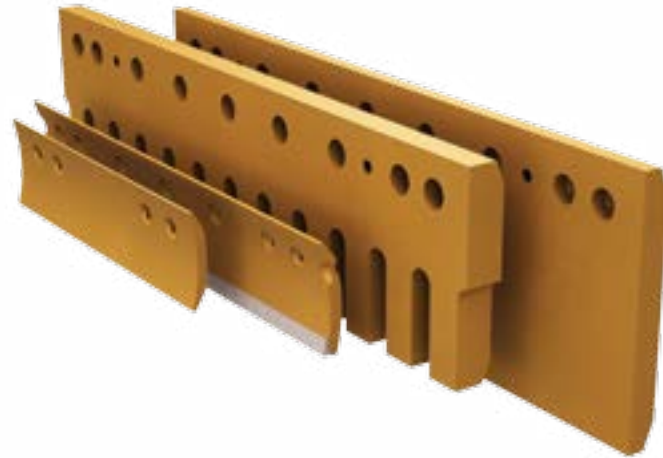

WHAT IS YOUR APPLICATION?



DEVELOPING A ROAD OR PERFORMING HEAVY MAINTENANCE

- A flat edge is best suited for this application. A better penetrating option is a flat serrated edge. A flat edge has limited ability to carry material forward.



GRADING HARD-PACKED GRAVEL, FROZEN EARTH AND ICE

- A serrated edge penetrates better than a continuous edge because it exerts more down pressure. A curved serrated edge penetrates better than a flat serrated edge with a forward mold board.



RECONDITIONING OR FINISH GRADING AN EXISTING ROAD SURFACE

- Curved edges penetrate the roadway while carrying existing material forward to leave a smooth flat surface. A better penetrating option is a curved serrated edge. A serrated edge will not leave as clean a roadway surface as a continuous edge.

MOTOR GRADER CUTTING EDGE OPTIONS

PARTNER WITH CATERPILLAR, EDGE OUT THE COMPETITION.

Caterpillar offers a wide range of cutting edges for motor graders. Each provides certain benefits when used in the appropriate application. Using the right edge is critical for enhancing production and keeping total costs to a minimum. The three factors to consider in choosing a cutting edge are shape, width and thickness.

There are two basic edge shapes—flat and curved—with serrated edges available in both configurations. In addition, the Cat GraderBits System dramatically expands the range of edge shape options. Cat offers two types of grader edges and three edge thicknesses for the 16M and 24M motor graders.

SUPERIOR DURABILITY, MORE OPTIONS

Cat DH-2 through-hardened steel edges are available in a variety of shapes and thicknesses to fit every application.

EXTENDED EDGE LIFE

Maximize your edge life with tungsten carbide edges.

MAXIMUM PENETRATION, MINIMUM WASTE

Cutting bit systems.



THROUGH-HARDENED CUTTING EDGES

Most Cat edges are through-hardened steel, which offers high-impact resistance. High-carbon edges have good surface hardness and perform well in high-abrasion, low-impact applications such as finish work. High-carbon edges will not withstand the impact level of a through-hardened edge.

For the most severe impact conditions, they can be installed over a 6" (152 mm) edge for improved resistance to tooth breakage.



FLAT

- Heavy road maintenance and pioneering
- Maximum strength and available wear material
- Best option for abrasion and impact resistance

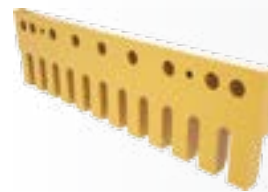

FLAT SERRATED

- Better penetration than a continuous edge (greater down pressure per inch of edge contact)
- Designed to penetrate packed gravel, frozen earth and ice
- For severe impact conditions, install over a 6" (152 mm) edge to reduce tooth breakage



CURVED

- Provides superior penetration and rolling action necessary for fine grading and finish work
- Finishing tolerances less than 1/4" (6 mm)—the best value may be in selecting a narrow and thin cutting edge



CURVED SERRATED

- A curved serrated edge penetrates better than a straight serrated edge with a forward mold board



EDGE WIDTH EQUALS WEAR MATERIAL

- An 8" (203 mm) edge provides twice the wear material as a 6" (152 mm) edge at about 35% more cost
- Hardware cost and R&I downtime are reduced by 50%

TUNGSTEN CARBIDE TILE CUTTING EDGES

Cat Tungsten Carbide Cutting Edges combine through-hardened steel with the wear resistance of tungsten carbide. When used in high-abrasion, low-impact applications, they can provide up to 20 times the life of a standard through-hardened edge. Fewer edge changes means less downtime and lower hardware costs.



TUNGSTEN CARBIDE EDGES

- Tungsten carbide edges have a continuous row of trapezoid-shaped carbide "tiles." This patented shape forms a leading / cutting edge
- Carbide tile bottom must be flat to the ground. 20° maximum tilt
- Max 5 mph/8kph
- Do not use on roads with large embedded rocks



FLAT EDGES

- Maximum strength and available wear material
- Longest wearing edge available in high abrasion and low impact

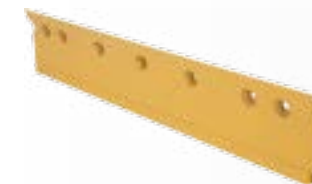

CURVED EDGES

- Curved-edge design improves penetration and rolling action
- Trapezoid-shaped tungsten carbide tile on leading edge stays sharp as it wears
- Shorter edge sections speed rotation and reduce "throw-away" due to edge crowning

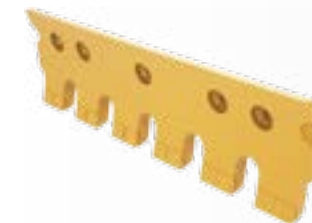

SERRATED EDGES

- Better penetration than a continuous edge (greater down pressure per in² of edge contact)
- No cast angle restrictions

TUNGSTEN CARBIDE INSERT CUTTING EDGES

Cat carbide insert edges offer long wear life in higher speed applications like state/county road snow removal. The tungsten carbide is brazed into a milled groove in the center of the edge. The design offers impact resistance and minimizes edge "crowning" in applications that require a level grading operation.



GRADERBIT SYSTEM

SMOOTH OUT THE TOUGHEST ROADWAYS IN A SINGLE PASS.

The Cat GraderBit edge system outperforms steel blades in high-production road reconditioning applications. Individual cutting bits are faced with tungsten carbide to form a serrated edge to penetrate and lift material to the surface immediately. As a result, most road maintenance jobs can be accomplished in a single pass.

MORE PRODUCTION, LESS WASTE

Cuts through tough and compact materials causing lower ripping resistance and horsepower loss.

CUSTOMIZABLE

Create edge patterns that deliver optimum performance.

LONGER LIFE

Up to 10x more wear life than a 10" edge.



INSTALLATION & REMOVAL

Operators can install the entire system in about an hour and field-replace individual bits in minutes without removing the moldboard. Varying bit widths allow you to create both serrated and continuous edge configurations. GraderBits do not require daily inspection like rotating bit systems.

1 Bit insertion into adapter board.



2 GraderBits are held in place with a snap ring.



3 Adapter boards bolt up to the moldboard like standard edges.



4 Keep bits perpendicular to the road surface. The cast angle is not to exceed 10°, penetration depth 1½" Max, Max 6 mph/10kph.



GRADERBIT SYSTEM

GraderBit adapter board options are 3' (914mm) and 4' (1219mm) sections. Two hole-spacing patterns are available to control aggregate flow. Standard boards are used for most roadways, and the mining board hold pattern is 50% wider to accommodate large aggregate in mine environments.



STANDARD BITS

- Baseline Bit - 30mm wide
- Moderate penetration
- Standard Board Bit Gap: 32mm
- Mining Board Bit Gap: 48mm



PENETRATION BITS

- Narrower than standard bit - 23 mm wide
- Wider gap allows larger aggregate to flow through
- Standard Board Bit Gap: 40mm
- Mining Board Bit Gap: 55mm



SHARP BITS

- 50% narrower than the standard bit - 15.5 mm wide
- Allows larger aggregate to flow through
- Standard Board Bit Gap: 45mm
- Mining Board Bit Gap: 62mm

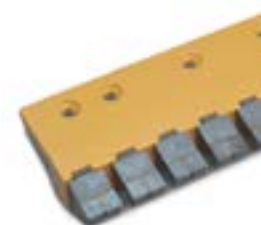

WIDE BITS

- Can configure as a continuous edge
- Twice as wide as the standard bit (60 mm)
- Standard Board Bit Gap: 3mm
- Mining Board Bit Gap: 18mm



MIX AND MATCH

- Mix and match bits to control the size of the aggregate left behind
- Use wide bits on the end of the moldboard to prevent excessive wear

MINING BIT SYSTEM

The Mining Bit System works like the GraderBit system, but is upgraded to withstand the extreme applications faced by large motor graders (16M and 24M).

DOUBLE CARBIDE, NO RESTRICTIONS

Protects the face and bottom of the bit, eliminating vast angle restrictions.

INTEGRATED DESIGN

Bit profile helps maintain proper grading angle.



ROTATING BIT SYSTEM

The rotating bit system outperforms steel blades in high-production road reconditioning applications. Individual cutting bits have tungsten carbide tips and form a serrated edge to penetrate and lift material to the surface immediately. As a result, most road maintenance jobs can be accomplished in a single pass

MORE PRODUCTION, LESS WASTE

Material is brought to the surface for reuse, reducing the expense of spreading new gravel.

NO RESTRICTIONS

No cast angle restriction.

EASY INSTALL & MAINTENANCE

Bits changed individually with no special tools.



ROTATING BIT SYSTEM

Rotating Scarifier Bits are self-sharpening for more uniform wear and long life. Cutting height is maintained as cutting tools may be rotated from position to position. Carbide bits can last as long as 5-10 sets of conventional grader blades.

Rotating Scarifier Bits are made for applications such as dirt and gravel reclamation, oil road reclamation, and snow and ice removal.

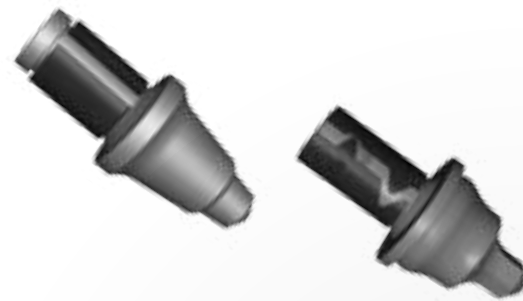

1" SHANK

- Smooth design

7/8" SHANK

- Engineered with flat sides that aid in bit rotation

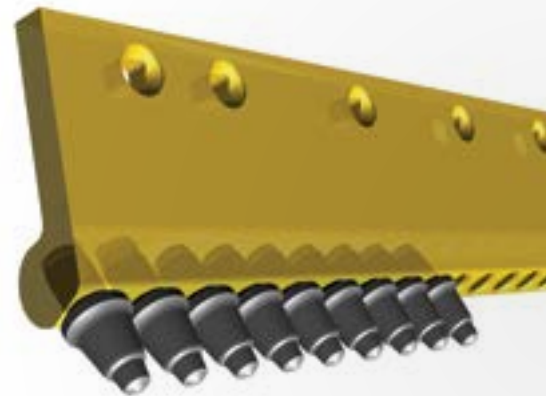

ADAPTER BOARDS

- Either 5/8" or 3/4" bolt hole punch
- 3' (914mm) – 21 bits
- 4' (1219mm) – 28 bits
- Standard Board uses 7/8" bit
- Heavy Duty board uses 1" bit



OPERATING TIPS

- 20° Board Angle
- Moldboard may vibrate and bits may not turn if angle is not correct

INSTALLATION & REMOVAL

Improve safety and simplify edge change-out. Cat cutting edges allow you to use a threaded bolt and link to remove and install sections. Even worn edges can be removed, because the threads are located in the back half of the hole.

1

Drilled and tapped holes.



2

Attach approved lifting device.

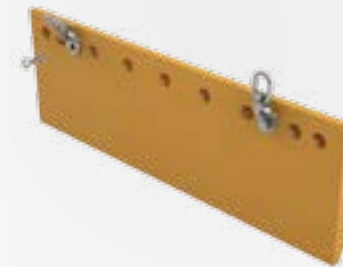

3

Lift.



OPERATING TECHNIQUES FOR REDUCED COST.

Through better management of the interface between machine and materials, operators can maximize productivity, lower machine operating costs and reduce cab vibration, improving operator comfort.



MOLDBOARD POSITION

- Start with moldboard 2" (4" for 24H) ahead of the edge
- Grade with cutting edge 90° to the road
- Maintain fixed angle to ensure constant edge thickness
- Laid back reduces penetration and can wear moldboard
- Frequent angle changes will shorten the edge life



SPEED AND EXCESSIVE DOWN PRESSURE

- Use accumulator to absorb shocks
- < 6mph/8kph speed
- Excess speed can cause edge slivering

Need penetration? Choose a thinner edge, a serrated edge or the Cat GraderBits System for the most compacted materials.



CROWNING

- Occurs when the cutting edge conforms to the material being graded
- A narrow and thin edge reduces the "throw away" material
- Extreme crowning may require a bit system

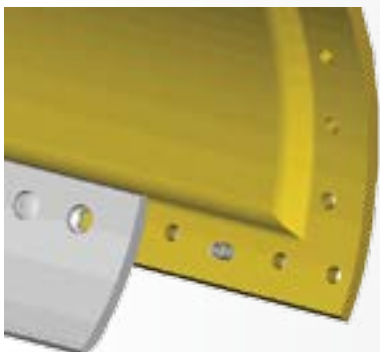

STANDARDIZE YOUR HARDWARE

- Moldboard bushings reduce 3/4" holes to 5/8"
- Simplify inventory and lower cost

END BIT SYSTEM

PUT AN END TO MOLDBOARD WEAR.

Made of through-hardened DH-2 steel for added strength and service life, Cat end bits protect moldboard edges from wear.



END BIT SYSTEM

Maximize moldboard life and lower repair costs. Use Cat end bits, overlays, repair plates and hardware to protect and repair your moldboards and working edges.



MOLDBOARD END BITS

- Recommended for all applications
- Made of through-hardened DH-2 steel for added strength and service life



OVERLAY END BITS

- Fit over existing end bit
- Recommended for applications such as ditching
- Add strength and limit corner wear
- When worn on one side, overlay end bits can be rotated for a second wear life



MOLDBOARD REPAIR PLATES

- Extend moldboard life with Cat Moldboard Repair Plates
- Routine monitoring and timely edge replacement can prevent damage
- When repair is needed, repair plates provide a way to extend moldboard life



HARDWARE

- When replacing ground engaging tools, always use Cat hardware regardless of the application
- Cat Grade 8 hardware is performance-matched to Cat G.E.T. in both strength and durability

RIPPER-SCARIFIER SYSTEM

GET MORE OUT OF YOUR GRADER.

Scarifier and ripper systems on motor graders can be used to improve road surfaces by lifting material from compacted and worn areas or by removing the "crowning" that causes excessive wear on cutting edges.

ENHANCE PRODUCTION

Loosen material to reduce grading time and fill voids while saving on edge wear.

EXTEND VERSATILITY

Reduce need for dozer ripping or cutting bit systems.



RIPPER-SCARIFIER COMPONENTS

Scarifiers can be mounted before the blade (V-Block design) or behind the machine (Straight Block design). Rear-mounted ripper-scarifiers are more versatile than forward-mounted configurations. Rip or scarify by changing shank position.



V-BLOCK

- Loosen compacted surfaces, rocky subgrades and frozen ground
- Fit ahead of the blade (mid mount)
- Holds up to 11 shanks and scarifies up to 46" (1168 mm) wide



STRAIGHT BLOCK

- Low-impact applications and shallow scarifying
- Higher allowable speed (up to 3rd gear) in shallow
- Holds up to 17 shanks and scarifies up to 72" (1828 mm) wide
- May be used as a mid-mount scarifier



SCARIFIER TIPS

- We offer three types of scarifier tips for surface reconditioning. Tip has a tapered design that secures it to the shank.
- Through-hardened tips for general purpose scarifying
- Heavy-Duty for deep penetration and extended distances
- A.R.M. for high abrasion/low impact extends tip life 3 to 5 times over through-hardened



SCARIFIER SHANKS

- Through-hardened and tempered to resist wear, bending and breakage
- Front or rear notch for V-Block or Straight Block
- Standard or extended lengths

RIPPER SYSTEMS

Caterpillar offers two options for the R350 ripper tip size class for 16M and 24M motor graders. Due to the extreme nature of maintaining haul roads, scarifiers are not offered on 16M and 24M.



CENTERLINE tips have equal wear material on both sides and can be reversed, which can extend the life and help maintain sharpness.

A.R.M.
OPTION
AVAILABLE



PENETRATION ripper tips have an aggressive angle to break through even the hardest surfaces and dig into the ground more effectively.

A.R.M.
OPTION
AVAILABLE



PENETRATION - SHARP tips are an intermediate length. They come factory sharpened to ensure maximum penetration.



INSTALLATION & REMOVAL

The J Series Tooth and Adapter system uses the standard pin and retainer system. The Tooth Pin Remover tool is available to make removal easier.

1 Place the tool on the tip and align the extractor with the pin.



2 Strike the tool with a hammer until the pin is removed.



HYDRAULIC EXCAVATORS

Cat Hydraulic Excavators are the most versatile machines on the jobsite, working in applications ranging from small landscaping projects to large surface extraction mines—and everywhere in between. Together, Cat buckets and G.E.T. make up the only bucket system designed and developed to optimize hydraulic excavator performance and your productivity. Rely on your Cat dealer for expert support and service for your specific application.



SYSTEM OVERVIEW

Hydraulic excavators are extremely versatile machines used for a variety of purposes, from grading to mass excavation to demolition work. A hydraulic excavator's main work tool is a bucket, but these machines can also be equipped hydraulic couplers to pick up a variety of tools.

Balancing your desired productivity/penetration with the wear life of your system is critical. Excessive wear material can reduce productivity and increase fuel burn. Cat hydraulic excavator buckets and G.E.T. are designed as a balanced system to increase life while minimizing drag.



TIP SELECTION GUIDE

Even though bucket tips come in many shapes and sizes, you don't have to be an expert to choose the right ones. Use the chart below to determine if the material you're digging in is high, medium or low impact and abrasion—then find the balance you need among these three factors:

1 STRENGTH









The ability to withstand digging and penetrating shocks and high breakout forces

2 PENETRATION

The ability to penetrate tough material when it's tightly compacted, rocky or frozen

3 WEAR LIFE

The ability to withstand wearing, scouring and abrasive action of the material being handled

	IMPACT (material size)			ABRASION (tip life)
	SMALL HEX (311-319)	MEDIUM HEX (320-329)	LARGE HEX (336-390)	
LOW	 0 - 1" 0 - 25 mm	 0 - 3" 0 - 75 mm	 0 - 6" 0 - 150 mm	> 1,000 hours
MEDIUM	 1 - 3" 25 - 75 mm	 3 - 8" 75 - 200 mm	 6 - 12" 150 - 300 mm	250 - 1,000 hours
HIGH	 3+" 75 mm+	 8+" 200 mm+	 12+" 300 mm+	< 250 hours



K SERIES TIP & ADAPTER SYSTEM

MAXIMUM PRODUCTIVITY MEETS HAMMERLESS RETENTION.

Looking for a vertical retention tip and adapter system that stays sharper, changes easier and holds tighter? Choose the K Series system's twist-on design and vertical retainer, which together provide reliable retention and easy installation and removal.

IMPROVE YOUR PRODUCTIVITY

Low-profile shape provides optimal sharpness, penetration and digging ability throughout the tip life.

EXTEND LIFE

More wear material can effectively be used before the tips are changed, adding 10-15% more usable life.

INCREASE DURABILITY

The tip and adapter fit together precisely to reduce tip movement and adapter wear.

STAY SAFE & REDUCE MAINTENANCE COSTS

One-piece vertical retainer allows for hammerless installation and removal, with only standard, low-force tools needed.

SIMPLIFY INSTALLATION

Rails on both sides of the adapter and a twist-on design hold the tip in place, allowing for quicker installation.

K SERIES DRIVE-THROUGH TIP & ADAPTER SYSTEM

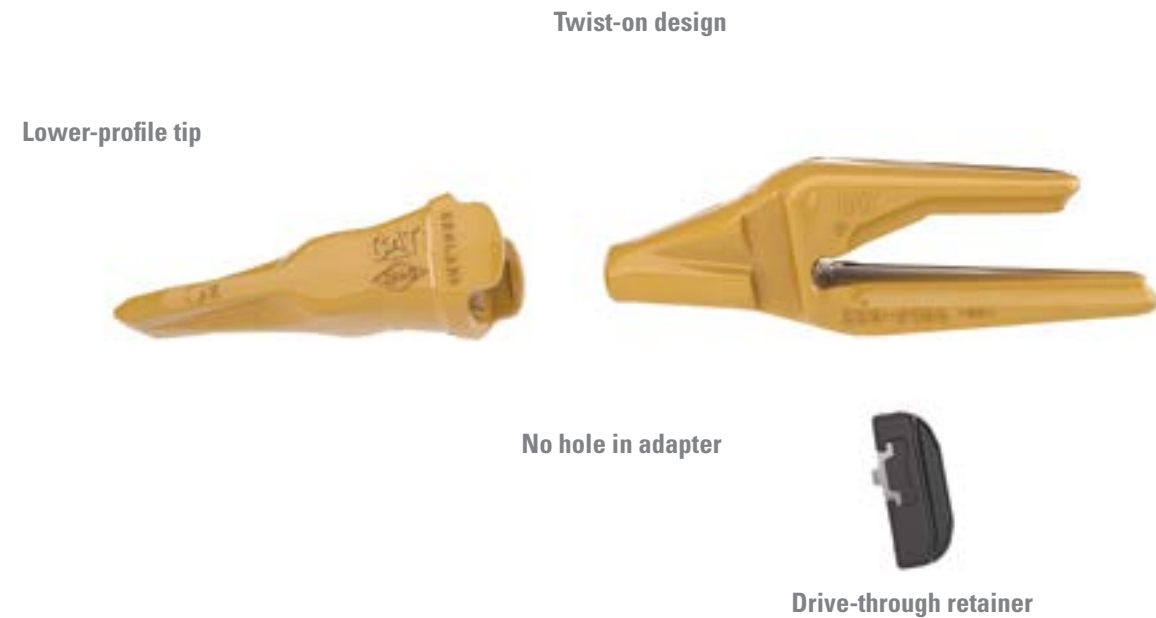

K SERIES HAMMERLESS TIP & ADAPTER SYSTEM

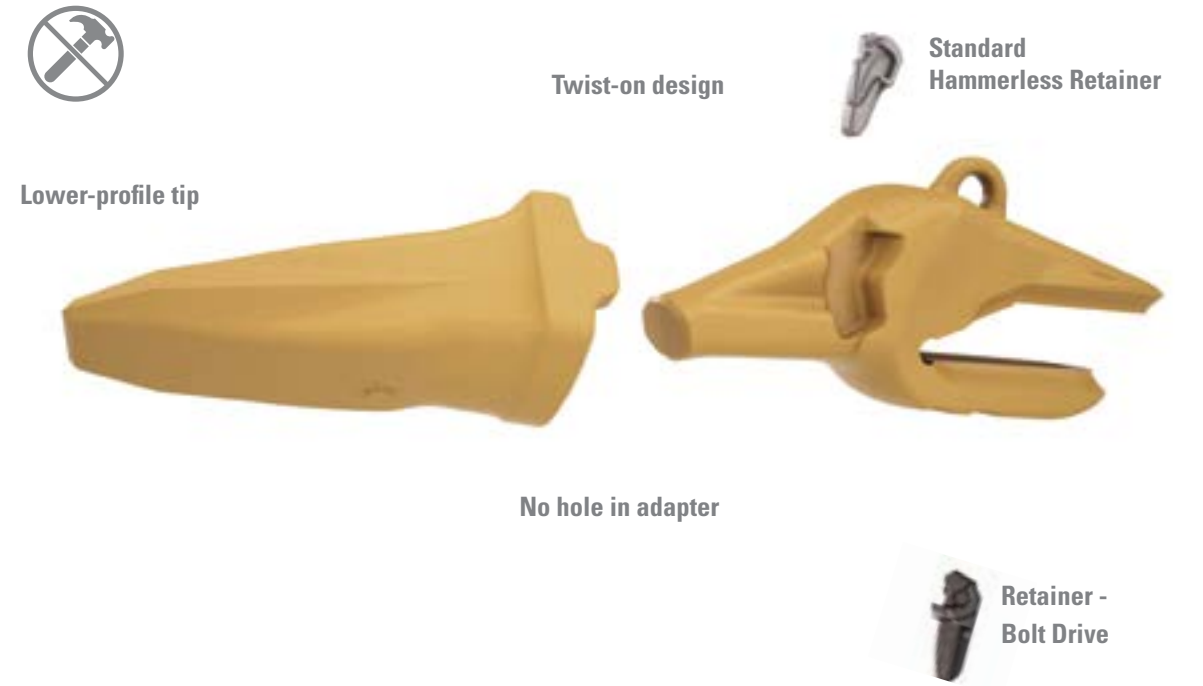

* Additional offering offered only for the extreme packing and slag applications.

INSTALLATION & REMOVAL

It's safe and easy—just use a standard pry tool and follow this three-step hammerless process:

Scan the QR code to the right to watch the installation video.

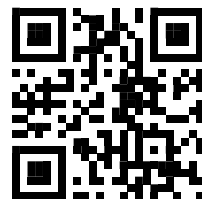

INSTALLATION & REMOVAL

It's safe and easy—just use a standard pry tool and follow this three-step hammerless process:

Scan the QR code to the right to watch the installation video.



1 INSERT RETAINER



2 HAMMER RETAINER



3 SECURE RETAINER



1 INSERT RETAINER



2 PRESS DOWN RETAINER



3 REMOVE RETAINER



K SERIES TIP OPTIONS

Below are the tip shapes best suited for the wide range of jobsite conditions performed by hydraulic excavators. We also offer additional K Series tips more commonly used with wheel loaders. Your Cat dealer can help you choose the one that offers the right balance of penetration and wear life for your application.

ABRASION

EXTRA DUTY



» **Extra Duty** and **Extra Duty Abrasion Resistant Material (A.R.M.)*** tips include approximately 60% more wear material in the tip body. The A.R.M. wears around the profile to increase penetration.

A.R.M.
OPTION
AVAILABLE

GENERAL DUTY



» **General Duty** tips are symmetrical and the baseline for other tip styles. All wear comparisons are to the General Purpose tip unless otherwise noted.

WIDE



» **Wide** tips are used to maintain smooth trench floors and in low-abrasion, easy-to-penetrate material.

PENETRATION PLUS



» **Penetration Plus** tips feature 25% more wear material and a leading edge with 25% less cross-sectional area. They self-sharpen as they wear.

PENETRATION



» **Penetration** tips are ideal for densely compacted materials. They feature a leading edge with 60% less cross-sectional area—allowing for maximum penetration—and a single center rib that self-sharpens as it wears. These tips are available with A.R.M.*

A.R.M.
OPTION
AVAILABLE

SPIKE



» **Spike** tips are used to achieve maximum penetration. They are typically used in cohesive material and stay sharp during the life of the tip.

DOUBLE SPIKE



» **Double Spike** tips are used the corner positions with the spike tips for hard-to-penetrate, fracturable materials.

IMPACT

*Abrasion Resistant Material (A.R.M.) is a welding process that bonds very hard tungsten carbide particles to Cat G.E.T. to create a protective shield over the component. Typically, the A.R.M. process doubles wear life—and can last even longer in some applications.

K SERIES ADAPTER OPTIONS

All K Series adapters feature rails on both sides of the nose for a twist-on design that stays in place during installation.

MACHINE COMPATIBILITY

EXCAVATOR	LINKAGE	SIZE CLASS
315	N/A	K80, K90
318	N/A	K80, K90
320	Reach	K80, K90
	Mass Excavation	K90, K100
324	Reach	K90, K100
	Mass Excavation	K100, K110
329	Reach	K90, K100
	Mass Excavation	K100, K110
336	Reach	K100, K110
	Mass Excavation	K110, K130
349	Reach	K110, K130
	Mass Excavation	K130
374	Reach	K150
	Mass Excavation	K170
390	Reach	K150
	Mass Excavation	K170





J SERIES TIP & ADAPTER SYSTEM

SIDE-PIN SECURITY WHEN YOUR APPLICATION DEMANDS IT.

Great performance and proven reliability over time—that's what you get with this classic horizontal retention system, a staple in the construction and mining industries.

BOOST YOUR VERSATILITY

Industry-standard side-pinned design performs across a variety of applications.

ENHANCE YOUR RELIABILITY

Weld-on adapters offer excellent retention.

IMPROVE SAFETY & MAINTENANCE TIME

Ability to retrofit means you can use the hammerless CapSure™ system.

J SERIES TIP & ADAPTER SYSTEM



Rock Chisel Tip

INSTALLATION & REMOVAL

Simply use the standard pin and retainer system—and make removal even easier with our Tip Pin Remover tool.*

1 Place the tool on the tip and align the extractor with the pin.



2 Strike the tool with a hammer until the pin is removed.



3 Place the tool over the tip (A), locate the pin in the hole of the holder (B) and strike the tool (C).



J SERIES TIP OPTIONS

Below are the tip shapes best suited for the wide range of jobsite conditions performed by hydraulic excavators. We also offer additional J Series tips more commonly used with wheel loaders. Your Cat dealer can help you choose the one that offers the right balance of penetration and wear life for your application.

ABRASION ↑	HEAVY DUTY LONG	» Heavy Duty Long and Heavy Duty Abrasion Resistant Material (A.R.M.)* tips include approximately 60% more wear material in the tip body. The A.R.M. wears around the profile to increase penetration.	A.R.M. OPTION AVAILABLE
	LONG (GENERAL DUTY)	» Long tips are symmetrical and the baseline for other tip styles. All wear comparisons are to the Long tip unless otherwise noted.	
	WIDE	» Wide tips are used to maintain smooth trench floors and in low-abrasion, easy-to-penetrate material.	
	PENETRATION PLUS	» Penetration Plus tips feature 30% more wear material and 25% less cross-sectional area. They self-sharpen as they wear.	
	PENETRATION	» Penetration and Penetration A.R.M.* tips are ideal for densely compacted materials. They feature a leading edge with approximately 50% less cross-sectional area and a single center rib for strength—allowing for maximum penetration.	A.R.M. OPTION AVAILABLE
	SPIKE	» Spike tips are used to achieve maximum penetration. They are typically used in cohesive material and stay sharp during the life of the tip.	
	SPIKE CORNER	» Spike Corner tips can be used in the corner position with sharp center tips.	
IMPACT ↓	DOUBLE SPIKE	» Double Spike tips are used the corner positions with the spike tips for hard-to-penetrate, fracturable materials.	

*Abrasion Resistant Material (A.R.M.) is a welding process that bonds very hard tungsten carbide particles to Cat G.E.T. to create a protective shield over the component. Typically, the A.R.M. process doubles wear life—and can last even longer in some applications.

J SERIES MACHINE COMPATIBILITY

EXCAVATOR	LINKAGE	SIZE CLASS
312	N/A	J250, J300
315	N/A	J300, J350
318	N/A	J300, J350
320	Reach	J300, J350, J400
	Mass Excavation	J400, J460
324	Reach	J400, J460
	Mass Excavation	J460, J550
329	Reach	J400, J460
	Mass Excavation	J460, J550
336	Reach	J460, J550
	Mass Excavation	J550
349	Reach	J550
	Mass Excavation	J550
374	Reach	J600
	Mass Excavation	J700
390	Reach	J600
	Mass Excavation	J700, J800



HAMMERLESS TIP & ADAPTER SYSTEM FEATURING CAPSURE RETENTION

LOSE THE HAMMER, NOT THE FLEXIBILITY.

Simplify bucket tip replacement with hammerless CapSure retention. These tips are matched to side-pin adapters, allowing the flexibility to use our conventional pin retention if your application demands it.

LOWER OPERATING COSTS

Side-pin retrofit design used on J-style adapters means the pin is reusable.

ENHANCE JOBSITE SAFETY & MAINTENANCE TIME

A 3/4-inch retainer lock requires no special tools and allows for hammerless installation and removal.

CHANGE OUT TIPS QUICKLY & EASILY

Positive stop is cast into the tip to prevent over-rotation—just turn 180 degrees to lock or unlock.

SPEED UP YOUR INSTALLATION TIME

Tip and retainer are one system, so there's no special assembly or extra pieces.



HAMMERLESS TIP & ADAPTER SYSTEM FEATURING CAPSURE RETENTION



Scan the QR code to the right to watch the installation video.

INSTALLATION & REMOVAL

It's fast, easy and safe with the CapSure locking system—just follow these four simple steps:

1 Insert pin and washer into the adapter hole.

2 Slide the tip onto the adapter.

3 Tighten 180° into the locked position with a 3/4" ratchet.

4 Remove by loosening 180° to the unlocked position.

CAPSURE TIP OPTIONS

We offer four CapSure tip options designed for a range of jobsite conditions. Your Cat dealer can help you choose the one that offers the right balance of penetration and wear life for your application.

ABRASION	HEAVY DUTY ABRASION <p>» Heavy Duty Abrasion tips are ideal for high-abrasion applications like sand, gravel and shot rock. They have the maximum amount of wear material—approximately 145% more—and the tip base features 35% more surface area than Heavy Penetration tips.</p>
	HEAVY PENETRATION <p>» Heavy Penetration tips are ideal for high-impact, hard-to-penetrate materials. They feature approximately 120% more material in the high wear area as well as a sharp spade design with 70% less cross-sectional area on the leading edge than Heavy Duty Abrasion tips.</p>
	HEAVY DUTY <p>» Heavy Duty tips are the baseline for other tips. All wear comparisons are to the Heavy Duty tip unless otherwise noted.</p>
	PENETRATION PLUS <p>» Penetration Plus tips feature 30% more wear material and 25% less cross-sectional area. They self-sharpen as they wear.</p>
IMPACT	

MACHINE COMPATIBILITY

EXCAVATOR	LINKAGE	SIZE CLASS
336	Reach	N/A
	Mass Excavation	J550 (Retrofit)
349	Reach	J550 (Retrofit)
	Mass Excavation	J550 (Retrofit)
374	Reach	J600 (Retrofit)
	Mass Excavation	J700 (Retrofit)
390	Reach	J600 (Retrofit)
	Mass Excavation	J700 (Retrofit), J800 (Retrofit)

BASE EDGE SYSTEMS

FASTEST INSTALLATION TIMES IN THE INDUSTRY.

Cat base edge systems go through a series of carefully controlled manufacturing processes to deliver maximum strength, durability and long life. They come completely welded and assembled, dramatically shortening your installation and replacement time.

INCREASE DURABILITY

A consistent heat-treat process maximizes strength and resists abrasion. Shot blasting removes impurities that can cause inclusions on a weld, and controlled cooling reduces the chance of stress points.

SAVE INSTALLATION & REPLACEMENT TIME

Butterbead is applied to the back side of the base edge and the top strap of the corner adapter, so you can weld the edge onto the bucket without preheating.

OPTIMIZE MACHINE PERFORMANCE

Base edges are designed by Caterpillar engineers for optimal performance on specific machines.



BASE EDGE SYSTEMS

Base edge replacement involves replacing a base edge assembly, which includes adapters welded in from the factory, or replacing a bolt-on cutting edge base edge, which comes with factory-drilled holes for bolt-on G.E.T. Choose from three shapes (base edge for BOCE, straight and spade base edge assemblies) to get the right protection for your application.

GET MORE ACCURACY

Lasers place the adapters within 0.1 mm of specifications.

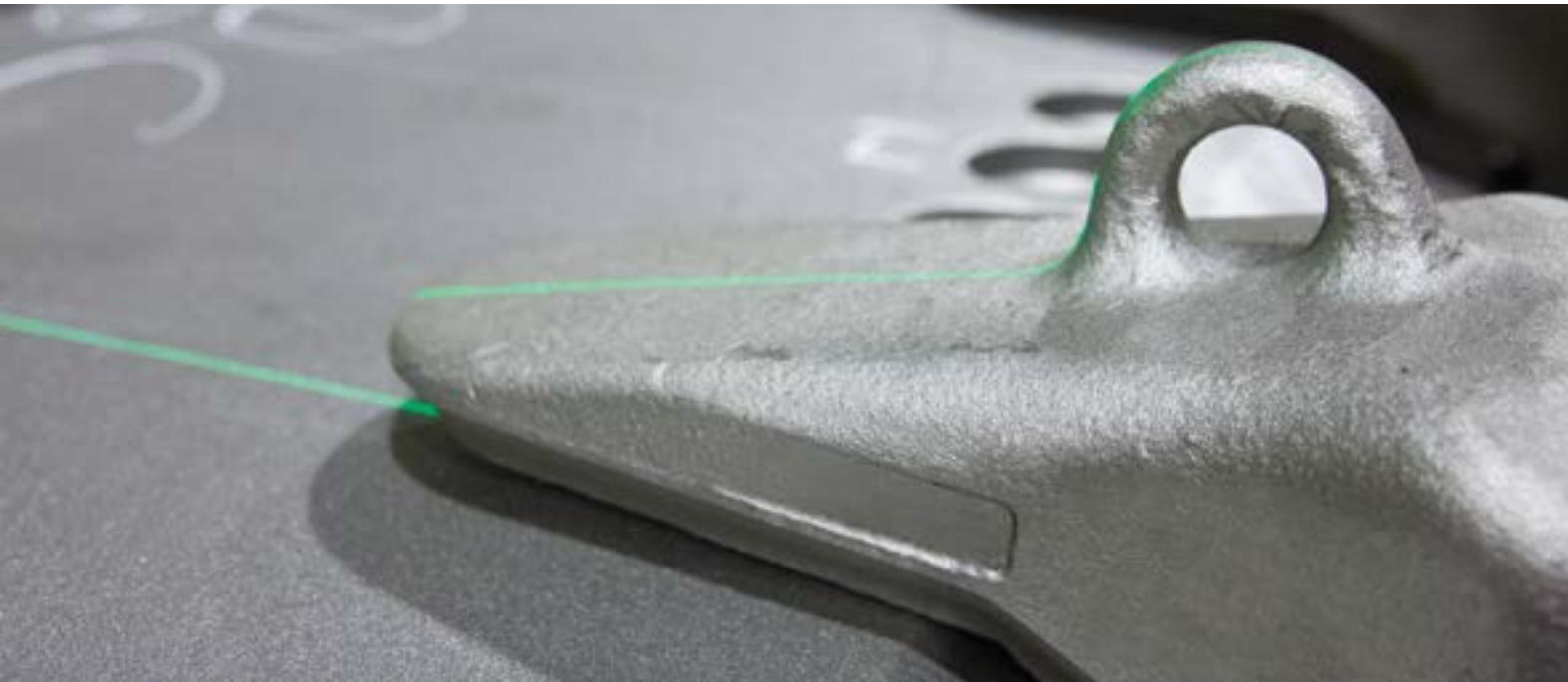

BOLT-ON CUTTING EDGE



STRAIGHT



SPADE



BUTTERBEAD BASE EDGE ASSEMBLY

DURABLE PROTECTION COMBINED WITH SHORTER INSTALLATION TIMES.

The protection you need, with no preheating required—that's what you get with butterbead weld prep. This technique, which involves applying a layer of weld to a heat-treated, higher hardness part, makes it possible to weld a base edge to a bucket without preheating the hardened part. Choose from two shapes (straight and spade) on cutting edges thicker than 50mm and three levels of build to get the right protection for your application.

SPEED UP YOUR INSTALLATION TIME

Weld prep eliminates the need for preheating, shortening edge installation time by 30-50%.

GET MORE DURABILITY

Base edges have the proper butterbead weld because it is applied in the factory.



BASE EDGE END PROTECTION (BEEP)

PROTECT YOUR CORNERS—WITHOUT CUTTING THEM.

Reduce base edge end wear and subsequent corner adapter weld erosion with our BEEP design. It makes adapter replacement on the edge much easier when it's time to rebuild the base edge assembly. BEEPs are available in a wide array of thicknesses and angles to fit 336-390 hydraulic excavators.

BOOST YOUR UPTIME

Through-hardened Rc ~45 (Br ~3.0) weldable steel is easily installed in the shop or the field.

EXTEND LIFE

Extended base edge end protects adapter corner welds.

SPEED UP INSTALLATION

Height and bevel are matched to the base edge, so there's no additional fabrication.

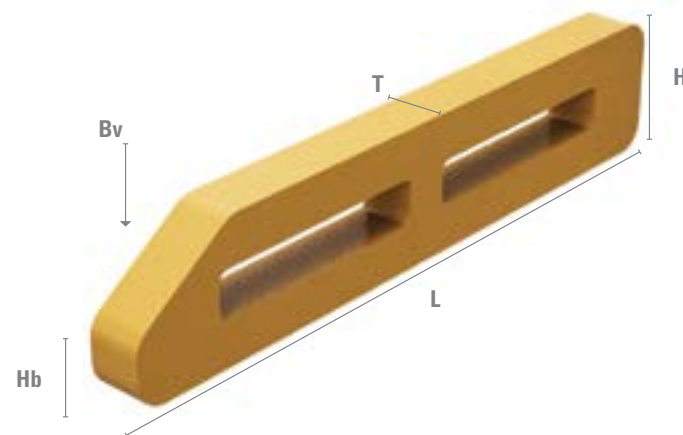

SIDE & EDGE PROTECTION

MAINTAIN YOUR PERFORMANCE EDGE.

Protect your bucket's structural integrity with sidebar protectors and shear blocks or increase penetration and performance with side cutters.

- » Sidebar Protectors
- » Side Cutters
- » Half Arrows
- » Segments
- » Top Covers



SIDEBAR PROTECTORS

Protect your bucket's structural integrity with sidebars and shear blocks.

INCREASE YOUR UPTIME

Shear block protects the pin from extreme loads and breakage, helping ensure sidebar protector retention.

CUT YOUR MAINTENANCE COSTS

Sidebar protector protects the bucket edge.

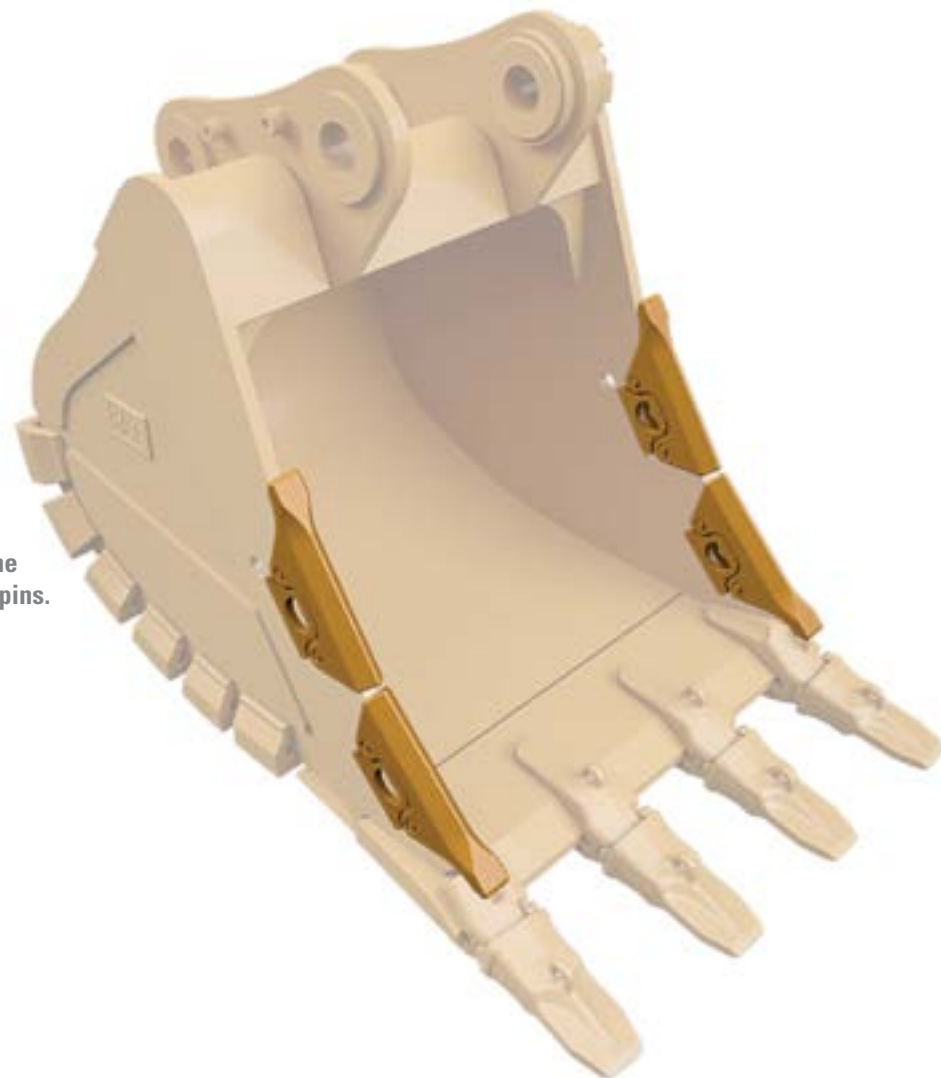

Shear block bears the loads instead of the pins.

SIDECUTTERS

Improve your bucket's performance while protecting your sidebars.

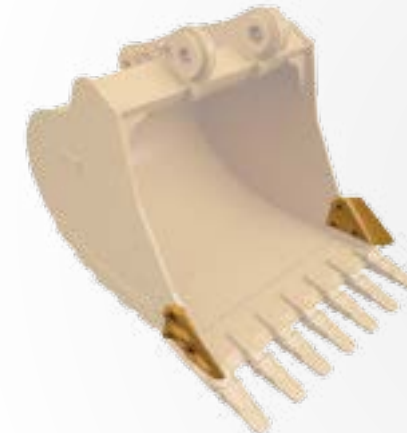

GENERAL PURPOSE SIDECUTTER

- » Effective in moderate-impact conditions.
- » Suitable for most soil conditions.
- » Provides a strong, wear-resistant surface to help protect bucket sides.
- » Extends bucket side width to match the teeth bite.

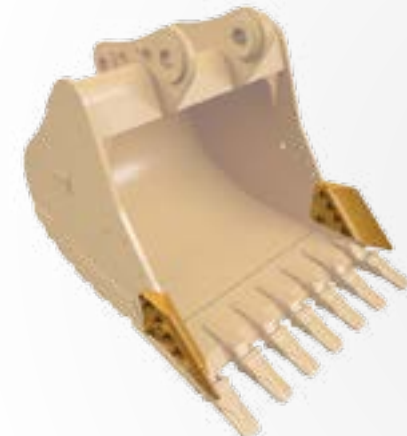

HEAVY DUTY SIDECUTTER

- » For tough digging conditions.
- » More wear material.
- » Covers more of the sidebar for enhanced protection of the bucket.
- » Scalloped profile improves bucket penetration and machine performance.

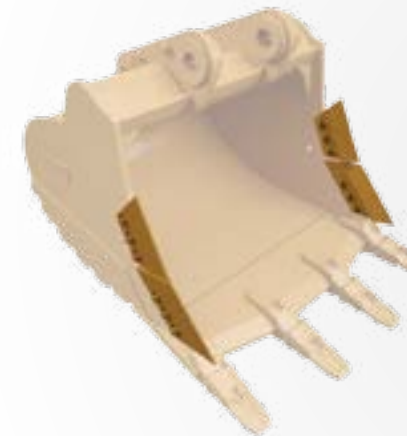

STRIKEOFF SIDECUTTER

- » Half arrow shape to provide better penetration than bare bucket.
- » Protects the lower bucket sides and corners.
- » For use in moderate-to-light conditions.
- » Can be stacked for more protection.

BOLT-ON HALF ARROWS, TOP COVERS & BOLT-ON CUTTING EDGES

Protect your investment in buckets and base edges with these flexible components. Half arrows allow for a smooth transition of material over the base edge to protect the leading edge. Top covers complement the half arrows to protect the base edge fully. And segments are ideal for moving re-handled materials with medium impact and medium abrasion.

SIMPLIFY MAINTENANCE

Individual pieces that protect the edge can be changed independently.

ENHANCE DURABILITY

Half arrows cover the leading edge for smooth material transition.

BOOST YOUR UPTIME

Top cover reduces wear on weld joints.



BUCKET SELECTION GUIDE

We offer four standard bucket durability categories suitable for any application. Each category is based on the bucket's intended durability when used in the recommended application and material.



GENERAL DUTY

- » For digging in low-impact, lower abrasion materials such as dirt, loam and mixed compositions of dirt and fine gravel. Example: Digging conditions in which General Duty tip life exceeds 800 hours.



HEAVY DUTY

- » For a wide range of impact and abrasion conditions including mixed dirt, clay and rock. Example: Digging conditions where Penetration Plus tip life ranges from 400 to 800 hours.
- » HD buckets are a good "center line" choice, or starting point, when application conditions are not well known.



SEVERE DUTY

» For higher abrasion conditions such as well-shot granite and caliche. Example: Digging conditions where tip life ranges from 200 to 400 hours with Penetration Plus tips.



EXTREME DUTY

» For very high-abrasion conditions including high quartzite granite. Example: Digging conditions where tip life is less than or equal to 200 hours with Extra Duty tips.

Typical 336-349 bucket



Typical 374-390 bucket

CHOOSING THE RIGHT DURABILITY.

Choosing the wrong bucket can easily reduce production, and increase operating costs by 10–20% or more. It can also cause unnecessary wear and fatigue for both machine and bucket.

Contact your local Cat dealer for more detailed information on choosing the right excavator, bucket and work tool attachment combinations to meet your application needs.

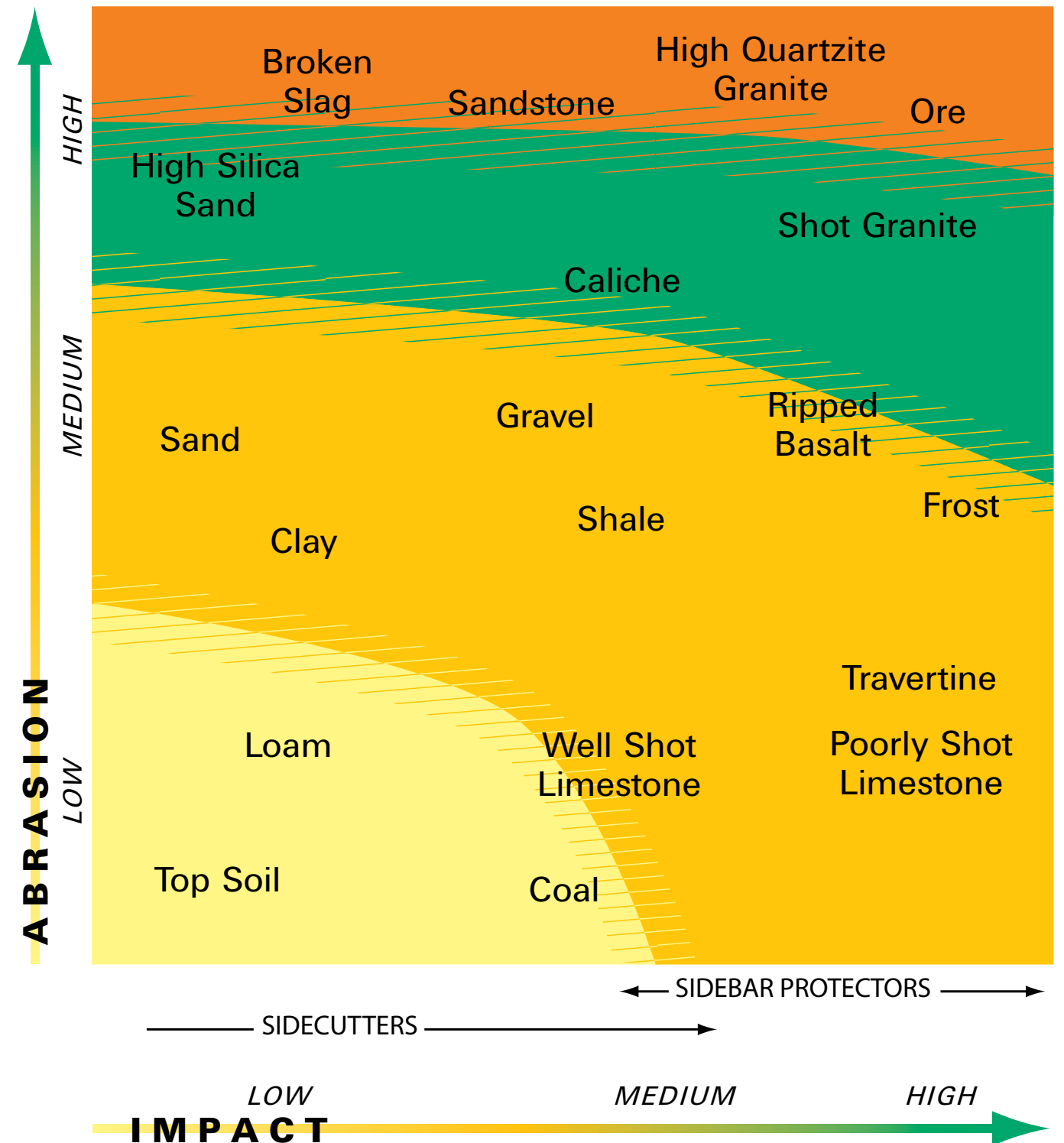

ADDITIONAL BUCKET STYLES

Several different bucket styles are available—each with a special purpose:

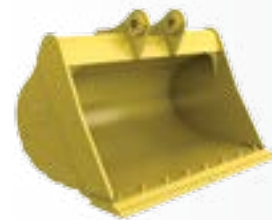

DITCH CLEANING

These buckets are designed for cleaning ditches, sloping, grading and other finish work. Their shallow depth and compact size make working in confined areas easier. Drainage holes allow liquid to empty so material dumps more easily. Ditch Cleaning Buckets are available for 311–336 excavators.

Tilt Buckets feature a full 45° of tilt in each direction, powered by two double-acting cylinders. Tilt Buckets are available for 311–329 excavators.



CENTER-LOCK™ PIN GRABBER PERFORMANCE

This bucket is designed with a patented recessed pin to provide maximum digging performance while keeping the versatility and convenience of a coupler. Tip radius is reduced and allows up to 10% improvement in breakout force when compared to a conventional pin-on bucket and coupler combination.

Center-Lock Pin Grabber Performance Buckets are available for 315–349 excavators, in General Purpose and Severe Duty durability.



POWER

Power Buckets are for use in abrasive applications where breakout force and cycle times are critical—and for use in materials such as tightly compacted mixed dirt and rock. (Not recommended for clay.) Breakout force is maximized due to decreased tip radius and increased pin spread. Machine cycle times in most material are improved over a standard bucket in a similar application.

Heavy Duty Power Buckets are available for 320–336 excavators.



WIDE TIP

Wide Tip Buckets are intended to perform best in low-impact materials such as dirt and loam where leaving a smoother floor and minimal spillage is necessary. The bucket is engineered to be used exclusively with Cat Wide Tips. Corner adapters face straight forward to create a smooth edge.

General Duty Wide Tip Buckets are available in widths from 24" to 78" for 311–349 excavators.



HIGH CAPACITY

High Capacity Buckets are designed and built for use in high-production truck-loading applications. With proper application and set up, these buckets will move more material in a minimal amount of passes — maximizing production.

High Capacity Buckets are available for 336–390 excavators, in General Duty durability.

CAT DEALER & BUCKET MANAGEMENT

CHOOSING CAT G.E.T. IS EASY.

Highly visual product line catalogs showcase the portfolio of products, while dealer capabilities influence the purchasing decision—sales, service, repair and technical support. Trust your Cat dealer to:

MAXIMIZE PRODUCTIVITY

Buckets and G.E.T. products are designed to meet your application requirements, rather than simply fit onto your machine.

IMPROVE PERFORMANCE

Get the most out of your bucket and G.E.T. with expert advice that helps you lower costs and reduce unscheduled maintenance.

SIMPLIFY MAINTENANCE

Tailored G.E.T. systems simplify your maintenance. We develop solutions that fit your expectations, including custom products.

IMPROVE PERFORMANCE

Bucket inspection programs help you monitor how your G.E.T. system is wearing so you can adapt to changes in application and operation.



HEX RIP AND LOAD

Using rippers mounted on large HEX is a cost-effective alternative to blasting in quarries and site development. In site development, rippers on smaller excavators and backhoe loaders can readily deal with asphalt, caliche and frozen ground.

IMPROVE YOUR PRODUCTIVITY

Increase productivity by adding efficiency and flexibility to your operation.

EXTEND LIFE

A through-hardened hammerless wear tip and shank protector extends wear life.

INCREASE DURABILITY

Upsized, hammerless adapters and tips accommodate higher loads and abrasion, while edge segments and top covers protect your base edge.



RIPPER-TO-BUCKET CHANGES ARE MADE HYDRAULICALLY IN LESS THAN 35 SECONDS.
This gives the operator complete flexibility to continually adjust ripping, sorting, and loading work.

SIMPLE CHANGES

Pull material down and change bucket quickly and easily.

BLAST FREE

Ripper allows you to work without blasting in areas with unstable land or sound regulations.

1



2



3



4



5



6



WEAR PARTS & A.R.M.

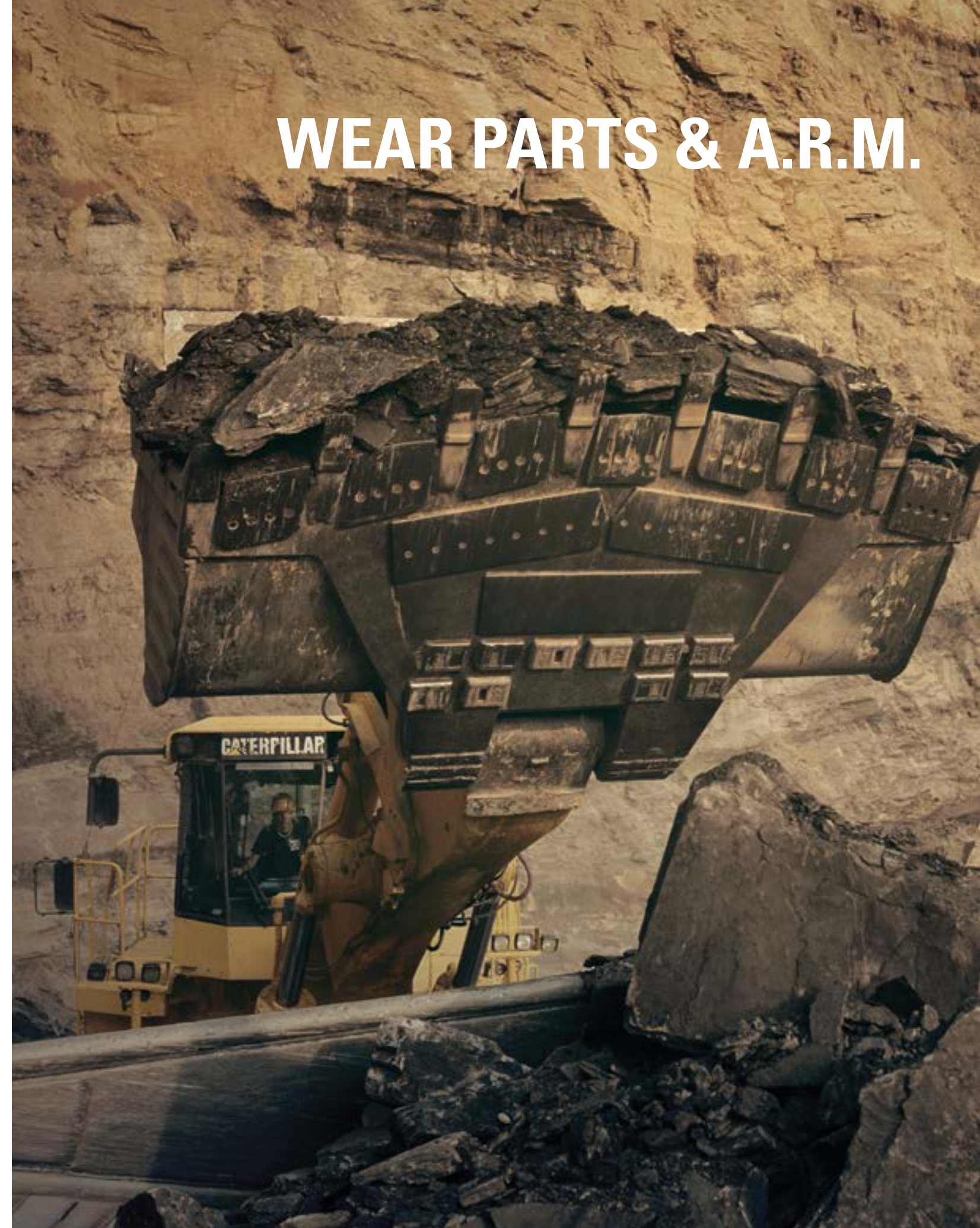

MECHANICALLY ATTACHED WEAR PLATE SYSTEM (MAWPS)

Safeguard wear areas with this hammerless system—available for a wide variety of applications.

INCREASE YOUR UPTIME

Two minute change-out—no hammer required.



LOWER YOUR INVENTORY COSTS

Flexible, versatile system welds to flat and curved surfaces.

SIMPLIFY INSPECTIONS

Wear indicator holes allow for quick and easy inspections, reducing maintenance time.

EXTEND WEAR LIFE

You can install the system perpendicular to material flow, then rotate it for more wear material.

RETENTION WITHOUT THE RISK.

Retention components are located within the base plate, where they're shielded from wear and load—eliminating the risk of wear plates falling off.



CHOOSE THE LOWEST-COST WEAR PROTECTION PER HOUR.

MAWPS VERSUS STEEL PLATES

When you choose MAWPS instead of steel wear plates, you can see cost savings as high as 44%, thanks to significantly lower labor and replacement costs.



TOTAL ANNUAL COSTS WITH STEEL PLATES

	PARTS	LABOR	TOTAL
Installation costs	\$4,000	\$1,200	\$5,200
Replacement costs (2x per year)	\$8,000	\$2,400	\$10,400
			\$15,600 or \$7.80/hour



TOTAL ANNUAL COSTS WITH MAWPS

	PARTS	LABOR	TOTAL
Installation costs	\$4,000	\$600	\$4,600
Replacement costs (2x per year)	\$4,000	\$83	\$4,083
			\$8,683 or \$4.34/hour

SOLID MAWPS

EASY INSTALLATION & REMOVAL

Save time and money with MAWPS' two-minute installation and removal.

1 Weld the adapter perpendicular to material flow for maximum wear material (or parallel to flow with the Cat logo on top for maximum coverage).



2 Position the wear plate over the base plate and slide the wear plate onto the base plate.



3 Install one end of the compression retainer with the plug and pry it into place with an 8mm-wide small pry bar.



4 Clean, use pry bar to remove the compression retainer, and slide the wear plate off the base plate.



Reduce maintenance hours with MAWPS' easy-to-use wear indicator holes. Just look, then rotate or replace.

Scan the QR code to the right to watch the installation video.



DESIGN SOLUTIONS FOR YOUR BUCKET.

With solid MAWPS, you can enhance protection while keeping machine weight to a minimum. Choose a layout designed by Caterpillar engineers for your specific machine or application to maximize your productivity. Cat dealers can access the global library of MAWPS layouts.



SIZE	MACHINE
50 Series	5230, 994
40 Series	993, 5130, R2900
30 Series (available with A.R.M.)	992, 990, 5080, 374-390
	R1700, R1600
20 Series (available with A.R.M.)	980 and down
	365 and down
	Trucks
10 Series	972 and down
	320-349
	R1300



SKELETAL MAWPS

STAY COVERED ACROSS YOUR PASS MATCH.

Quick and easy to install, skeletal MAWPS protect the rear portion of truck bodies to help you maximize uptime. A through-hardened DH-2 wear plate slides onto a weld-on base plate and is held in place with a patented compression retainer, trapping materials from any direction.

TRAP MORE MATERIAL

The skeletal wear plate traps material in and between plates, allowing for material-on-material wear instead of wear on steel body liner products.

EXTEND WEAR LIFE

Because the compression retainer is positioned low in the base plate, more of the wear plate can be worn away before you need to replace it.

SIMPLIFY REMOVAL & INSTALLATION

You can typically replace worn wear plates in two minutes or less without hammering or welding.

INCREASE YOUR FLEXIBILITY

Available in standard and heavy-duty sizes, skeletal MAWPS can be customized to fit virtually any truck body configuration—flat floor or dual slope.



TOTAL WEAR PROTECTION

INCREASED PRODUCTIVITY. FOR EVERY ENVIRONMENT. FOR EVERY APPLICATION.

Get the best available protection for every product on your site, from wheel loaders to cable shovels, with our Total Wear Protection line.



Chocky Bars, available in four shapes, feature a V-groove design that can be bent around a radius. They can be separated or modified in length. The inset of the Cat logo allows for the trapping of fine material in each section, extending the life of the wear material itself. Chocky bars come in four sizes.



Wear Buttons, designed for applications that optimize the round profile, trap material to provide material-on-material wear. Wear buttons are available in four sizes.



Wear Blocks feature a zigzag inset design that allows for material-on-material wear. They prevent channel wear common in parallel grooves, delivering extended life in extreme operations.



Roll Bars protect the leading edge of dozers, loaders, mining shovels and other equipment, providing maximum wear protection while minimizing drag. Roll bars are available in three sizes.



Bolt Protectors help prevent hardware wear on cutting edges, top plates, sidebar protectors and more by allowing material to pack. They also allow for easier removal when replacing G.E.T.

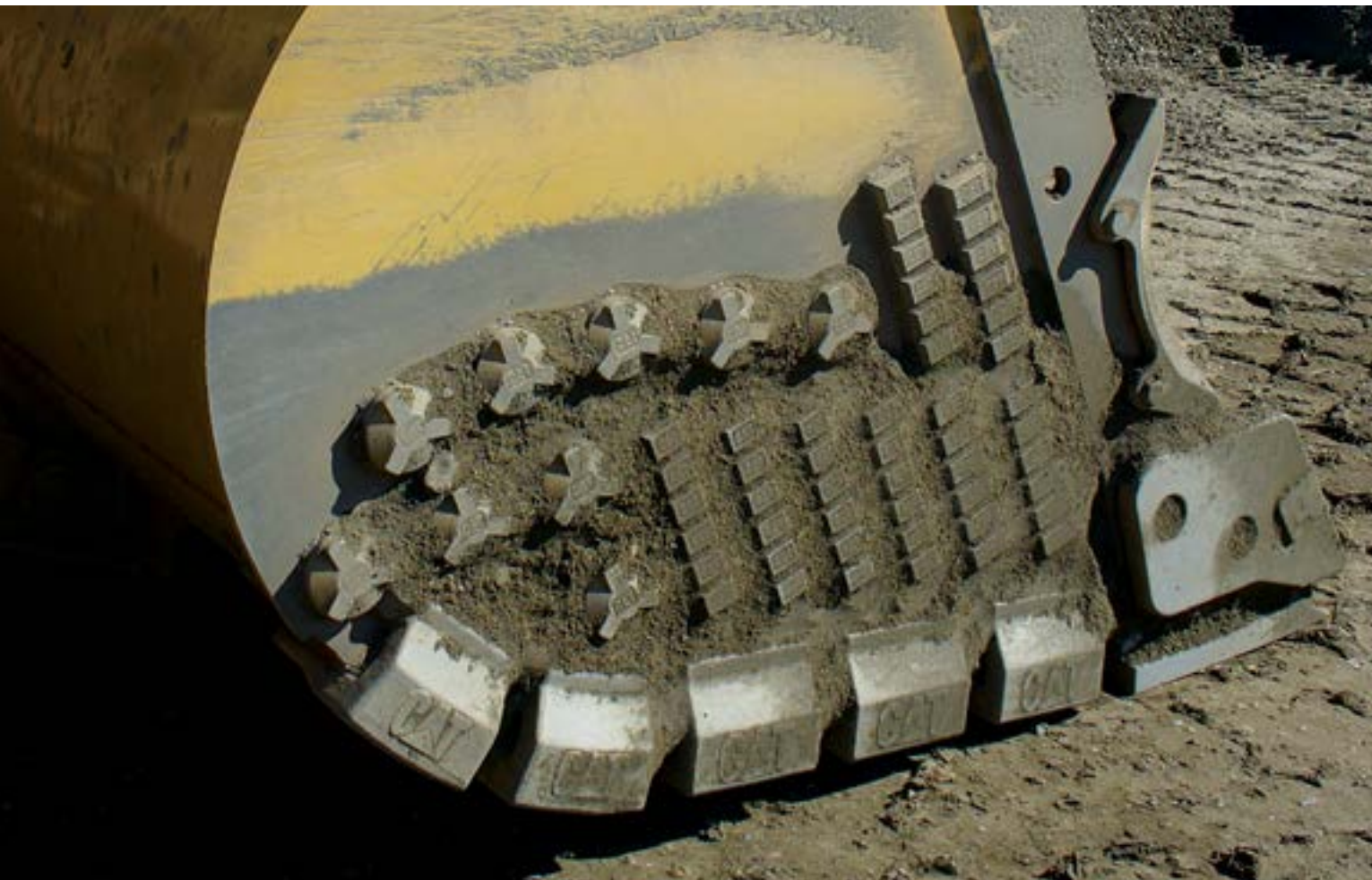

WELD-ON HEEL SHROUDS & HALF ARROW EDGES

WELD-ON HEEL SHROUDS

Weld-on heel shrouds protect the bottom and side of the bucket, concentrating extra wear material in the corner where it's needed most, and are ~400 Bn in hardness. Straight or curved shrouds come in three sizes, offering up to two inches of corner protection.



WELD-ON HALF ARROW EDGES

Weld-on half arrow edges can be used to customize a bucket with sidebar protection, as side cutters to improve penetration or as segments between teeth to reduce scalloping.



Chocky bars in application

ABRASION RESISTANT MATERIAL (A.R.M.)

Cat Abrasion Resistant Material is a coating made of extremely hard tungsten carbide particles that forms a protective shield over key wear surfaces. Cat G.E.T. with A.R.M. is ideal for high-abrasion, low-to-moderate impact applications—such as working in sand, gravel and other abrasive materials that can severely diminish G.E.T. wear life.

EXTEND YOUR WEAR LIFE

Tungsten carbide offers three to five times the life of through-hardened G.E.T.

LOWER YOUR COST PER HOUR

Self-sharpening wear pattern means fewer change-outs in the right applications.

EXAMPLE PARTS WITH A.R.M. APPLIED



Two-Strap K Series Adapter



J Series Penetration Tip



K Series Heavy Duty Tip



HARDNESS COMPARISON

MOHS HARDNESS ROCKWELL "C" HARDNESS

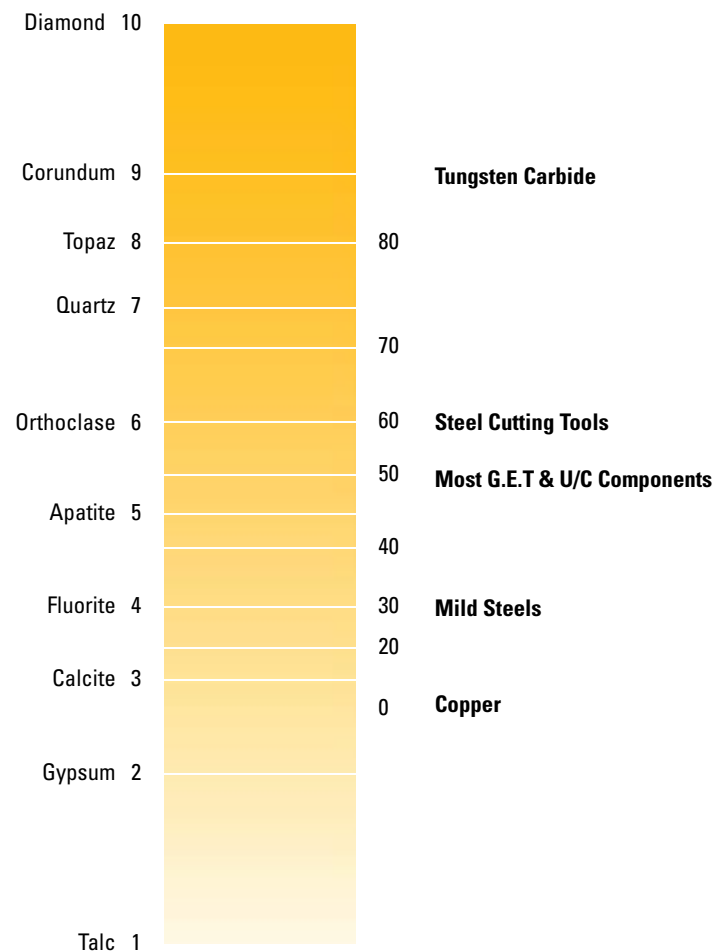

A.R.M.
OPTION
AVAILABLE

NOTE: Products available with the A.R.M. option feature this symbol.



PEBJ0078

© 2014 Caterpillar. All Rights Reserved.

CAT, CATERPILLAR, BUILT FOR IT, their respective logos, "Caterpillar Yellow", the "Power Edge" trade dress as well as corporate and product identity used herein, are trademarks of Caterpillar and may not be used without permission.

